

3) HX300 L LONG REACH

· 10.2 m (33' 6") BOOM and 7.85 m (25' 9") ARM

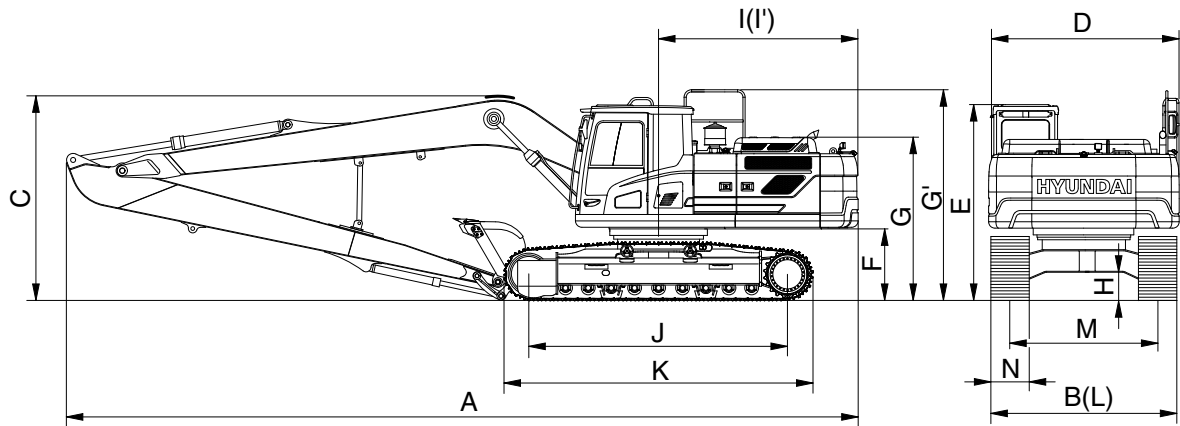

290F2SP04

Description	Unit	Specification
Operating weight	kg (lb)	33070 (72910)
Bucket capacity (SAE heaped), standard	m ³ (yd ³)	0.52 (0.68)
Overall length	A	14560 (47' 9")
Overall width, with 800 mm shoe	B	3400 (11' 2")
Overall height of boom	C	3560 (11' 8")
Superstructure width	D	2980 (9' 9")
Overall height of cab	E	3030 (9' 11")
Ground clearance of counterweight	F	1190 (3' 11")
Overall height of engine hood	G	2600 (8' 6")
Overall height of handrail	G'	3340 (10' 11")
Minimum ground clearance	H	500 (1' 8")
Rear-end distance	I	3120 (10' 3")
Rear-end swing radius	I'	3200 (10' 6")
Distance between tumblers	J	4030 (13' 3")
Undercarriage length	K	4940 (16' 2")
Undercarriage width	L	3400 (11' 2")
Track gauge	M	2600 (8' 6")
Track shoe width, standard	N	800 (31' 5")
Travel speed (low/high)	km/hr (mph)	3.3/5.9 (2.1/3.7)
Swing speed	rpm	10.2
Gradeability	Degree (%)	35 (70)
Ground pressure (800 mm shoe)	kgf/cm ² (psi)	0.48 (6.83)
Max traction force	kg (lb)	26500 (58420)

2) HX300 L LONG REACH

· 10.2 m (33' 6") BOOM

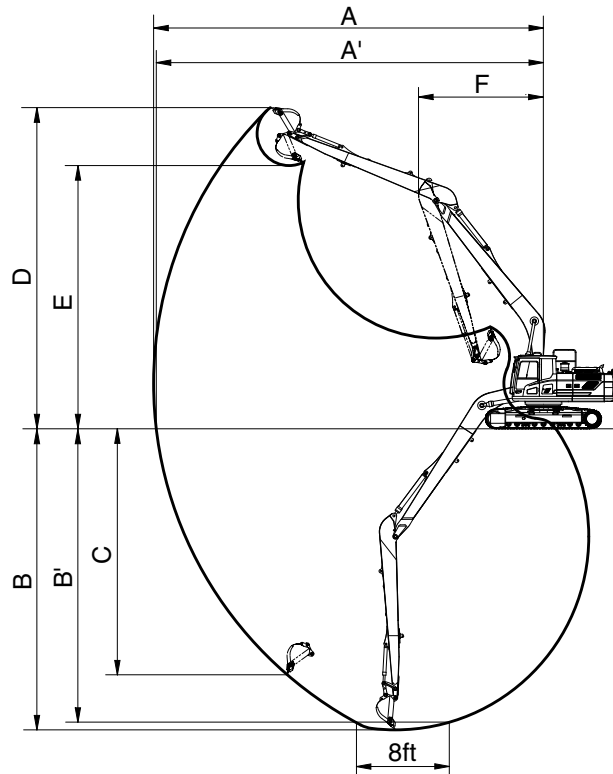

290F2SP07

Description		7.85 m (25' 9") Arm
Max digging reach	A	18510 (60' 9")
Max digging reach on ground	A'	18400 (60' 4")
Max digging depth	B	14820 (48' 7")
Max digging depth (8 ft level)	B'	14690 (48' 2")
Max vertical wall digging depth	C	12020 (39' 5")
Max digging height	D	14500 (47' 7")
Max dumping height	E	12190 (40' 0")
Min swing radius	F	6250 (20' 6")
Bucket digging force	SAE	70 kN
		7100 kgf
		15650 lbf
	ISO	80 kN
		8200 kgf
		18080 lbf
Arm crowd force	SAE	47.1 kN
		4800 kgf
		10580 lbf
	ISO	48.1 kN
		4900 kgf
		10800 lbf

2) HX300 L LONG REACH

















Item	HX300 L LONG REACH	
	kg	lb
Upperstructure assembly	15390	33930
Main frame weld assembly	2720	6000
Engine assembly	520	1150
Aftertreatment assy	94	210
Main pump assembly	140	310
Main control valve assembly	220	490
Swing motor assembly	350	770
Hydraulic oil tank assembly	270	600
Fuel tank assembly	235	520
Counterweight	7000	15450
Cab assembly	490	1080
Lower chassis assembly	11750	25900
Track frame weld assembly	3750	8270
Swing bearing	435	960
Travel motor assembly	360	790
Turning joint	54	120
Sprocket	83	180
Track recoil spring	225	500
Idler	260	570
Carrier roller	35	80
Track roller	56	120
Track-chain assembly (800 mm standard triple grouser shoe)	2350	5180
Front attachment assembly (10.2 m boom, 7.85 m arm, 0.52 m ³ SAE heaped bucket)	5930	13070
10.2 m boom assembly	2980	6570
7.85 m arm assembly	1340	2960
0.52 m ³ SAE heaped bucket	460	1010
Boom cylinder assembly	270	600
Arm cylinder assembly	360	790
Bucket cylinder assembly	140	310
Bucket control link assembly	110	240

3) HX300 L LONG REACH

(1) 10.2 m (33' 6") boom, 7.85 m (25' 9") arm equipped with 0.52 m³ (SAE heaped) bucket and 800 mm (32") triple grouser shoe.

•  : Rating over-front

•  : Rating over-side or 360 degree

Load point height		Load radius														At max. reach				
		6.0 m (20.0 ft)		7.5 m (25.0 ft)		9.0 m (30.0 ft)		10.5 m (35.0 ft)		12.0 m (40.0 ft)		13.5 m (45.0 ft)		15.0 m (50.0 ft)		Capacity		Reach		
																		m (ft)		
13.5 m	kg																*1780	*1780	14.13	
45.0 ft	lb																*3920	*3920	(46.4)	
12.0 m	kg																*1800	*1800	15.27	
40.0 ft	lb																*3970	*3970	(50.1)	
10.5 m	kg													*1060	*1060	*1840	1800	16.18		
35.0 ft	lb													*2340	*2340	*4060	3970	(53.1)		
9.0 m	kg													*1520	*1520	*1880	1580	16.89		
30.0 ft	lb													*3350	*3350	*4140	3480	(55.4)		
7.5 m	kg													*1900	*1900	*1830	*1830	*1930	1410	17.44
25.0 ft	lb													*4190	*4190	*4030	*4030	*4250	3110	(57.2)
6.0 m	kg													*2050	*2050	*2030	1990	*1990	1290	17.83
20.0 ft	lb													*4520	*4520	*4480	4390	*4390	2840	(58.5)
4.5 m	kg									*2350	*2350	*2230	*2230	*2160	1900	*2060	1190	18.08		
15.0 ft	lb									*5180	*5180	*4920	*4920	*4760	4190	*4540	2620	(59.3)		
3.0 m	kg					*3280	*3280	*2900	*2900	*2630	*2630	*2440	2270	*2310	1800	2100	1130	18.20		
10.0 ft	lb					*7230	*7230	*6390	*6390	*5800	*5800	*5380	5000	*5090	3970	4630	2490	(59.7)		
1.5 m	kg	*6200	*6200	*4720	*4720	*3860	*3860	*3310	*3310	*2930	2650	*2660	2120	*2470	1700	2060	1090	18.19		
5.0 ft	lb	*13670	*13670	*10410	*10410	*8510	*8510	*7300	*7300	*6460	5840	*5860	4670	*5450	3750	4540	2400	(59.7)		
Ground /line	kg	*7360	6790	*5500	5030	*4410	3880	*3700	3070	*3220	2460	*2880	1990	*2630	1610	2060	1070	18.04		
	lb	*16230	14970	*12130	11090	*9720	8550	*8160	6770	*7100	5420	*6350	4390	*5800	3550	4540	2360	(59.2)		
-1.5 m	kg	*8210	6230	*6140	4620	*4880	3580	*4060	2850	*3490	2300	*3090	1870	2750	1520	2080	1080	17.76		
-5.0 ft	lb	*18100	13730	*13540	10190	*10760	7890	*8950	6280	*7690	5070	*6810	4120	6060	3350	4590	2380	(58.3)		
-3.0 m	kg	*8750	5910	*6610	4340	*5260	3360	*4360	2680	*3720	2170	3180	1770	2680	1460	2150	1120	17.33		
-10.0 ft	lb	*19290	13030	*14570	9570	*11600	7410	*9610	5910	*8200	4780	7010	3900	5910	3220	4740	2470	(56.9)		
-4.5 m	kg	*9050	5760	*6910	4180	*5530	3220	4520	2560	3710	2080	3110	1710	2640	1420	2270	1200	16.75		
-15.0 ft	lb	*19950	12700	*15230	9220	*12190	7100	9960	5640	8180	4590	6860	3770	5820	3130	5000	2650	(55.0)		
-6.0 m	kg	*9130	5730	*7050	4120	5580	3150	4450	2500	3660	2030	3080	1680	2640	1410	2450	1310	15.99		
-20.0 ft	lb	*20130	12630	*15540	9080	12300	6940	9810	5510	8070	4480	6790	3700	5820	3110	5400	2890	(52.5)		
-7.5 m	kg	*9010	5790	*7040	4130	5570	3150	4450	2490	3660	2030	3090	1690			2720	1500	15.04		
-25.0 ft	lb	*19860	12760	*15520	9110	12280	6940	9810	5490	8070	4480	6810	3730			6000	3310	(49.3)		
-9.0 m	kg	*8670	5930	*6840	4220	*5570	3200	4500	2540	3720	2080					*3100	1780	13.83		
-30.0 ft	lb	*19110	13070	*15080	9300	*12280	7050	9920	5600	8200	4590					*6830	3920	(45.4)		
-10.5 m	kg	*8060	6160	*6410	4380	*5220	3330	*4310	2660	*3530	2210					*3270	2250	12.31		
-35.0 ft	lb	*17770	13580	*14130	9660	*11510	7340	*9500	5860	*7780	4870					*7210	4960	(40.4)		
-12.0 m	kg	*7070	6490	*5640	4630	*4550	3550													
-40.0 ft	lb	*15590	14310	*12430	10210	*10030	7830													
-13.5 m	kg	*5460	*5460	*4260	*4260															
-45.0 ft	lb	*12040	*12040	*9390	*9390															

- Note
1. Lifting capacity are based on SAE J1097 and ISO 10567.
 2. Lifting capacity of the ROBEX series does not exceed 75% of tipping load with the machine on firm, level ground or 87% of full hydraulic capacity.
 3. The load point is a hook located on the back of the bucket.
 4. * indicates load limited by hydraulic capacity.

6. BUCKET SELECTION GUIDE

1) GENERAL BUCKET

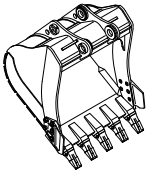
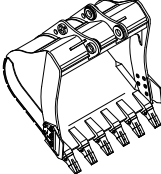
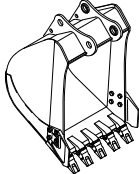
		
1.27, 1.50 m ³ SAE heaped bucket	1.73, 1.85 m ³ SAE heaped bucket	★0.52 m ³ SAE heaped bucket

Capacity		Width		Weight	Recommendation				
					6.25 m (20' 6") boom				10.2 m (33' 6") boom
SAE heaped	CECE heaped	Without side cutter	With side cutter		2.1 m arm (6' 11")	2.5 m arm (8' 2")	3.05 m arm (10' 0")	3.75 m arm (12' 4")	7.85 m arm (25' 9")
1.27 m ³ (1.66 yd ³)	1.11 m ³ (1.45 yd ³)	1325 mm (52.2")	1410 mm (55.5")	1100 kg (2430 lb)	○	○	○	⊙	
1.50 m ³ (1.96 yd ³)	1.30 m ³ (1.70 yd ³)	1515 mm (59.6")	1600 mm (63.0")	1180 kg (2600 lb)	○	○	⊙	●	
1.73 m ³ (2.26 yd ³)	1.51 m ³ (1.98 yd ³)	1605 mm (63.2")	1690 mm (66.5")	1280 kg (2820 lb)	⊙	⊙	●	●	
1.85 m ³ (2.42 yd ³)	1.61 m ³ (2.11 yd ³)	1700 mm (66.9")	1780 mm (70.1")	1330 kg (2930 lb)	⊙	●	●	●	
★0.52 m ³ (0.68 yd ³)	0.45 m ³ (0.59 yd ³)	945 mm (37.2")	1020 mm (40.2")	460 kg (1010 lb)					⊙

★ : Long reach bucket

○ Applicable for materials with density of 2000 kgf/m³ (3370 lbf/yd³) or less

⊙ Applicable for materials with density of 1600 kgf/m³ (2700 lbf/yd³) or less

● Applicable for materials with density of 1100 kgf/m³ (1850 lbf/yd³) or less

※ These recommendations are for general conditions and average use.

Work tools and ground conditions have effects on machine performance.

Select an optimum combination according to the working conditions and the type of work that is being done.

Consult your Hyundai dealer for information on selecting the correct boom-arm-bucket combination.

2) HEAVY DUTY AND ROCK-HEAVY DUTY BUCKET

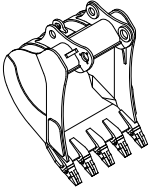
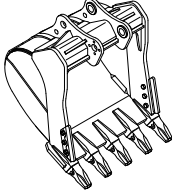
	
<p>◆ 1.27 m³ SAE ◆ 1.46 m³ SAE heaped bucket</p>	<p>◆ 1.33 m³ SAE ◆ 1.50 m³ SAE heaped bucket</p>

Capacity		Width		Weight	Recommendation			
					6.25 m (20' 6") boom			
SAE heaped	CECE heaped	Without side cutter	With side cutter		2.1 m arm (6' 11")	2.5 m arm (8' 2")	3.05 m arm (10' 0")	3.75 m arm (12' 4")
◆ 1.27 m ³ (1.66 yd ³)	1.11 m ³ (1.45 yd ³)	1380 mm (54.3")	-	1290 kg (2840 lb)	○	○	⊙	⊙
◆ 1.46 m ³ (1.91 yd ³)	1.28 m ³ (1.67 yd ³)	1535 mm (60.4")	-	1380 kg (3040 lb)	⊙	⊙	⊙	●
◆ 1.33 m ³ (1.74 yd ³)	1.16 m ³ (1.52 yd ³)	1420 mm (55.9")	-	1470 kg (3240 lb)	⊙	⊙	⊙	●
◆ 1.50 m ³ (1.96 yd ³)	1.30 m ³ (1.70 yd ³)	1550 mm (61.0")	-	1550 kg (3420 lb)	⊙	⊙	●	●

◆ : Heavy duty bucket

◆ : Rock-Heavy duty bucket

○ Applicable for materials with density of 2000 kg/m³ (3370 lbf/yd³) or less

⊙ Applicable for materials with density of 1600 kg/m³ (2700 lbf/yd³) or less

● Applicable for materials with density of 1100 kg/m³ (1850 lbf/yd³) or less

7. UNDERCARRIAGE

1) TRACKS

X-leg type center frame is integrally welded with reinforced box-section track frames. The design includes dry tracks, lubricated rollers, idlers, sprockets, hydraulic track adjusters with shock absorbing springs and assembled track-type tractor shoes with triple grousers.

2) TYPES OF SHOES

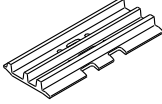
Model	Shapes		Triple grouser			
						
HX300 L	Shoe width	mm (in)	600 (24)	700 (28)	800 (32)	900 (36)
	Operating weight	kg (lb)	30200 (66580)	30770 (67840)	31150 (68670)	31530 (69510)
	Ground pressure	kgf/cm ² (psi)	0.58 (8.25)	0.51 (7.25)	0.45 (6.40)	0.41 (5.83)
	Overall width	mm (ft-in)	3200 (10' 6")	3300 (10' 10")	3400 (11' 1")	3500 (11' 5")
HX300 NL	Shoe width	mm (in)	600 (24)	-	-	-
	Operating weight	kg (lb)	30000 (66140)	-	-	-
	Ground pressure	kgf/cm ² (psi)	0.58 (8.25)	-	-	-
	Overall width	mm (ft-in)	2990 (9'10")	-	-	-
HX300 L LONG REACH	Shoe width	mm (in)	-	-	800 (32)	-
	Operating weight	kg (lb)	-	-	33070 (72910)	-
	Ground pressure	kgf/cm ² (psi)	-	-	0.48 (6.83)	-
	Overall width	mm (ft-in)	-	-	3400 (11' 2")	-
HX300 L HIGH WALKER	Shoe width	mm (in)	600 (24)	700 (28)	800 (32)	★710 (28)
	Operating weight	kg (lb)	33040 (72840)	33610 (74100)	33990 (74930)	34520 (76100)
	Ground pressure	kgf/cm ² (psi)	0.64 (9.10)	0.56 (7.96)	0.49 (6.97)	0.56 (7.96)
	Overall width	mm (ft-in)	3470 (11' 5")	3570 (11' 9")	3670 (12' 0")	3580 (11' 9")

★ : Double grouser

3) NUMBER OF ROLLERS AND SHOES ON EACH SIDE

Item	Quantity
Carrier rollers	2 EA
Track rollers	9 EA
Track shoes	48 EA

4) SELECTION OF TRACK SHOE

Suitable track shoes should be selected according to operating conditions.

Method of selecting shoes

Confirm the category from the list of applications in **table 2**, then use **table 1** to select the shoe. Wide shoes (categories B and C) have limitations on applications. Before using wide shoes, check the precautions, then investigate and study the operating conditions to confirm if these shoes are suitable.

Select the narrowest shoe possible to meet the required flotation and ground pressure. Application of wider shoes than recommendations will cause unexpected problem such as bending of shoes, crack of link, breakage of pin, loosening of shoe bolts and the other various problems.

※ **Table 1**

Track shoe	Specification	Category
600 mm triple grouser	Standard	A
700 mm triple grouser	Option	B
710 mm double grouser	Option	B
800 mm triple grouser	Option	C
900 mm triple grouser	Option	C
800 mm triple grouser (long reach)	Standard	C

※ **Table 2**

Category	Applications	Precautions
A	Rocky ground, river beds, normal soil	<ul style="list-style-type: none"> Travel at low speed on rough ground with large obstacles such as boulders or fallen trees
B	Normal soil, soft ground	<ul style="list-style-type: none"> These shoes cannot be used on rough ground with large obstacles such as boulders or fallen trees Travel at high speed only on flat ground Travel slowly at low speed if it is impossible to avoid going over obstacles
C	Extremely soft ground (swampy ground)	<ul style="list-style-type: none"> Use the shoes only in the conditions that the machine sinks and it is impossible to use the shoes of category A or B These shoes cannot be used on rough ground with large obstacles such as boulders or fallen trees Travel at high speed only on flat ground Travel slowly at low speed if it is impossible to avoid going over obstacles

8. SPECIFICATIONS FOR MAJOR COMPONENTS

1) ENGINE

Item	Specification
Model	Cummins QSB6.7
Type	4-cycle turbocharged, charge air cooled diesel engine
Cooling method	Water cooling
Number of cylinders and arrangement	6 cylinders, in-line
Firing order	1-5-3-6-2-4
Combustion chamber type	Direct injection type
Cylinder bore × stroke	107 × 124 mm (4.21" × 4.88")
Piston displacement	6700 cc (409 cu in)
Compression ratio	17.3 : 1
Rated net horse power (SAE J1349)	230 Hp at 1950 rpm (171 kW at 1950 rpm)
Rated gross horse power (SAE J1995)	242 Hp at 1950 rpm (180 kW at 1950 rpm)
Maximum torque	100.9 kgf · m (729.8 lbf · ft) at 1500 rpm
Engine oil quantity	23.1 ℓ (6.1 U.S. gal)
Wet weight	520 kg (1146 lb)
High idling speed	1950 ± 50 rpm
Low idling speed	800 ± 100 rpm
Rated fuel consumption	152.1 g/Hp · hr at 1950 rpm
Starting motor	Denso 24 V-4.8 kW
Alternator	Denso 24 V-95 A
Battery	2 × 12 V × 160 Ah

2) MAIN PUMP

Item	Specification
Type	Variable displacement tandem axis piston pumps
Capacity	2 × 140 cc/rev
Maximum pressure	350 kgf/cm ² (4980 psi) [380 kgf/cm ² (5400 psi)]
Rated oil flow	2 × 273 ℓ/min (72.1 U.S. gpm / 60.1 U.K. gpm)

[] : Power boost

3) GEAR PUMP

Item	Specification
Type	Fixed displacement gear pump single stage
Capacity	15 cc/rev
Maximum pressure	40 kgf/cm ² (570 psi)
Rated oil flow	29.25 l /min (7.7 U.S. gpm/6.4 U.K. gpm)

4) MAIN CONTROL VALVE

Item	Specification	
Type	10 spools	
Operating method	Hydraulic pilot system	
Main relief valve pressure	350 kgf/cm ² (4980 psi) [380 kgf/cm ² (5400 psi)] *1 350 kgf/cm ² (4980 psi) [Not applied power boost]	
Port relief valve pressure	Boom	400 kgf/cm ² (5690 psi)
	Arm	400 kgf/cm ² (5690 psi), *1 250 kgf/cm ² (3560 psi)
	Bucket	400 kgf/cm ² (5690 psi), *1 270 kgf/cm ² (3840 psi)

[] : Power boost *1 : Long reach only

5) SWING MOTOR

Item	Specification
Type	Axial piston motor
Capacity	156.9 cc/rev
Relief pressure	300 kgf/cm ² (4270 psi)
Braking system	Automatic, spring applied hydraulic released
Braking torque	84.4 kgf · m (610 lbf · ft) over
Brake release pressure	36.5 kgf/cm ² (519 psi) below
Reduction gear type	2 - stage planetary

6) TRAVEL MOTOR

Item	Specification
Type	Variable displacement axial piston motor
Capacity	282.6/156.9 cc/rev
Relief pressure	350 kgf/cm ² (4980 psi)
Braking system	Automatic, spring applied hydraulic released
Braking torque	134 kgf · m (969 lbf · ft)
Brake release pressure	17 kgf/cm ² (242 psi)
Reduction gear type	2-stage planetary

7) CYLINDER

Item		Specification
Boom cylinder	Bore dia × Stroke	∅ 140 × 1465 mm
	Cushion	Extend only
Arm cylinder	Bore dia × Stroke	∅ 150 × 1765 mm
	Cushion	Extend and retract
Bucket cylinder	Bore dia × Stroke	∅ 135 × 1185 mm
	Cushion	Extend only
Bucket cylinder (long reach)	Bore dia × Stroke	∅ 100 × 870 mm
	Cushion	Extend and retract

※ Discoloration of cylinder rod can occur when the friction reduction additive of lubrication oil spreads on the rod surface.

※ Discoloration does not cause any harmful effect on the cylinder performance.

8) SHOE

Item		Width	Ground pressure	Link quantity	Overall width
HX300 L	Standard	600 mm (24")	0.58 kgf/cm ² (8.25 psi)	48	3200 mm (10' 6")
	Option	700 mm (28")	0.51 kgf/cm ² (7.25 psi)	48	3300 mm (10' 10")
		800 mm (32")	0.45 kgf/cm ² (6.40 psi)	48	3400 mm (11' 1")
		900 mm (36")	0.41 kgf/cm ² (5.83 psi)	48	3500 mm (11' 5")
HX300 NL	Standard	600 mm (24")	0.58 kgf/cm ² (8.25 psi)	48	2990 mm (9' 10")
HX300 L LONG REACH	Standard	800 mm (32")	0.48 kgf/cm ² (6.83 psi)	48	3400 mm (11' 2")
HX300 L HIGH WALKER	Standard	600 mm (24")	0.64 kgf/cm ² (9.10 psi)	48	3470 mm (11' 5")
	Option	700 mm (28")	0.56 kgf/cm ² (7.96 psi)	48	3570 mm (11' 9")
		800 mm (32")	0.49 kgf/cm ² (6.97 psi)	48	3670 mm (12' 0")
		★710 mm (28")	0.56 kgf/cm ² (7.96 psi)	48	3580 mm (11' 9")

★ : Double grouser

9) BUCKET

Item	Capacity		Tooth quantity	Width	
	SAE heaped	CECE heaped		Without side cutter	With side cutter
HX300 L HX300 NL H/WALKER	1.27 m ³ (1.66 yd ³)	1.11 m ³ (1.45 yd ³)	5	1325 mm (52.2")	1410 mm (55.5")
	◆ 1.27 m ³ (1.66 yd ³)	1.11 m ³ (1.45 yd ³)	5	1380 mm (54.3")	-
	◆ 1.46 m ³ (1.91 yd ³)	1.28 m ³ (1.67 yd ³)	5	1535 mm (60.4")	-
	◆ 1.33 m ³ (1.74 yd ³)	1.16 m ³ (1.52 yd ³)	5	1420 mm (55.9")	-
	◆ 1.50 m ³ (1.96 yd ³)	1.30 m ³ (1.70 yd ³)	5	1550 mm (61.0")	-
	1.50 m ³ (1.96 yd ³)	1.30 m ³ (1.70 yd ³)	5	1515 mm (59.6")	1600 mm (63.0")
	1.73 m ³ (2.26 yd ³)	1.51 m ³ (1.98 yd ³)	6	1605 mm (63.2")	1690 mm (66.5")
	1.85 m ³ (2.42 yd ³)	1.61 m ³ (2.11 yd ³)	6	1700 mm (66.9")	1780 mm (70.1")
LONG REACH	0.52 m ³ (0.68 yd ³)	0.45 m ³ (0.59 yd ³)	5	945 mm (37.2")	1020 mm (40.2")

◆ : Heavy duty bucket

◆ : Rock-Heavy duty bucket

9. RECOMMENDED OILS

Use only oils listed below or equivalent.

Do not mix different brand oil.

Service point	Kind of fluid	Capacity ℓ (U.S. gal)	Ambient temperature °C (°F)						
			-50 (-58)	-30 (-22)	-20 (-4)	-10 (14)	0 (32)	10 (50)	20 (68)
Engine oil pan	Engine oil	23.1 (6.1)	★SAE 5W-40						
			SAE 30						
			SAE 10W						
			SAE 10W-30						
			SAE 15W-40						
DEF Tank	Mixture of urea and deionized water	42.5 (11.2)	ISO 22241, High-purity urea + deionized water (32.5:67.5)						
Swing drive	Gear oil	12 (3.2)	★SAE 75W-90						
Final drive		8.0×2 (2.1×2)	SAE 85W-140						
Hydraulic tank	Hydraulic oil	Tank : 190 (50) System : 330 (87)	★ISO VG 15						
			ISO VG 32						
			ISO VG 46						
			ISO VG 68						
Fuel tank	Diesel fuel★1	500 (132)	★ASTM D975 NO.1						
			ASTM D975 NO.2						
Fitting (grease nipple)	Grease	As required	★NLGI NO.1						
			NLGI NO.2						
Radiator (reservoir tank)	Mixture of antifreeze and soft water★2	40 (10.6)	Ethylene glycol base permanent type (50 : 50)						
			★Ethylene glycol base permanent type (60 : 40)						

SAE : Society of Automotive Engineers

API : American Petroleum Institute

ISO : International Organization for Standardization

NLGI : National Lubricating Grease Institute

ASTM : American Society of Testing and Material

★1 : Ultra low sulfur diesel

- sulfur content ≤ 15 ppm

★2 : Soft water

City water or distilled water

★ : Cold region

Russia, CIS, Mongolia